



Corrugated Cases - Our Service to You.

Corrugated cardboard is the most versatile of all packaging materials and is the most cost effective way of containing and protecting many goods.

Our range of cardboard boxes goes from small glossy finished printed point of sale boxes right up to Tri-wall pallet boxes.

We have a large range of boxes in stock but we believe our strength comes from our highly trained and experienced sales team. They can design your cases to accurately meet your requirements. We can often save money not only in the cost of the box but more significantly in the cost of transporting your goods safely to your customer.

It is our skill to consider the following information and then tailor a solution to you. We will then supply you the correct box in manageable quantities when you require them at the most competitive price.

Key considerations:

- Product weight and size
- Product strength,
- Puncture resistance
- Pallet size
- Postage/Haulage costs
- Variation in product size
- Packaging waste regulations
- Quantity of goods packed.
- Method of packing – manual or automatic filling line
- Visual function – transit packaging or point of sale packaging
- Legislation e.g. Chemical transport
- Distance to customer/transport type.

And we then use this information to specify:-

- Liner type (outside layer of box)
- Fluting type
- Board Grade (thickness of papers)
- Box size
- Box design (FEFCO range of box styles)
- Manufacturing run size/stockholding quantity
- Most efficient manufacturing plant for that box
- Certification requirements

Our Most Popular FEFCO Carton Formats

FEFCO is the European Federation of Corrugated Board Manufacturers. Here at Samuel Grant we can provide over 50 carton and box formats to suit a wide variety of applications. Here are just a small selection of the most common formats. Should your specific requirements not be represented here, please call our packaging specialists on 0113 270 7221.

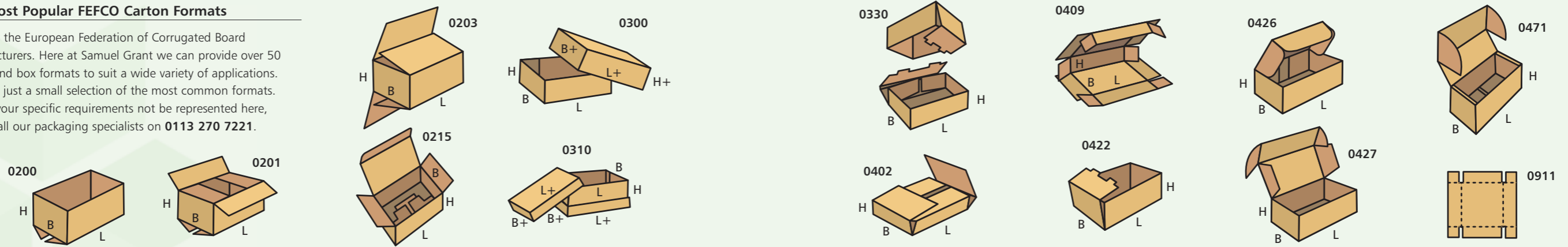

Mail Order Corrugated Cartons - CCBDC ▼

Our standard range of BDC and BDCM cartons comply accurately with mail order industry specifications.

- Supplied flat pack for self assembly and printed with contents tables to specific Mail Order company requirements.
- Excellent range of standard size boxes ideal for general purpose packing and storage.



Should your packaging requirements not be available within our product brochure we will gladly source your specific needs.

Die Cut Cartons - CCDC ▼

Available in a wide selection of corrugated board and produced to customer's own individual specification. Die cutting allows very complex designs to be cut from corrugated sheets resulting in cases that fold together to form almost any shape.

- Can be printed to customer's own design.



Die Cut Carton assembled

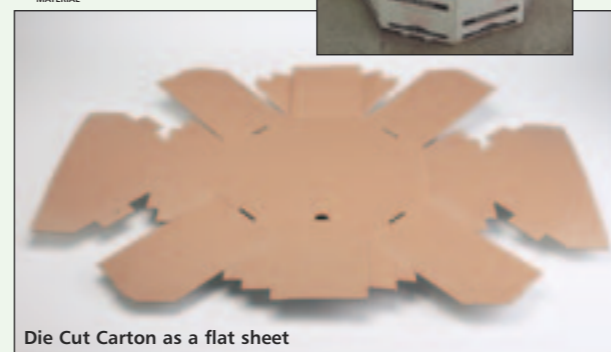

Die Cut Carton as a flat sheet

Corrugated Cartons - CC ▼

With a large range of both single and double wall cartons always in stock Samuel Grant can provide the majority of your carton requirements immediately. Should we be unable to supply your needs from our stock range we will be happy to provide bespoke cartons to suit your specifications.

- Supplied flat pack for self assembly.



Standard Corrugated Cartons

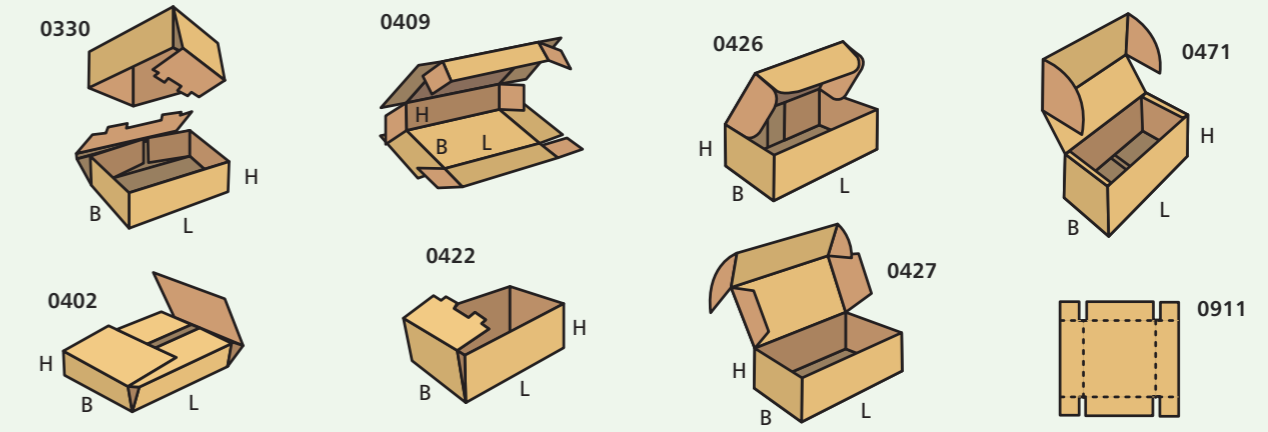
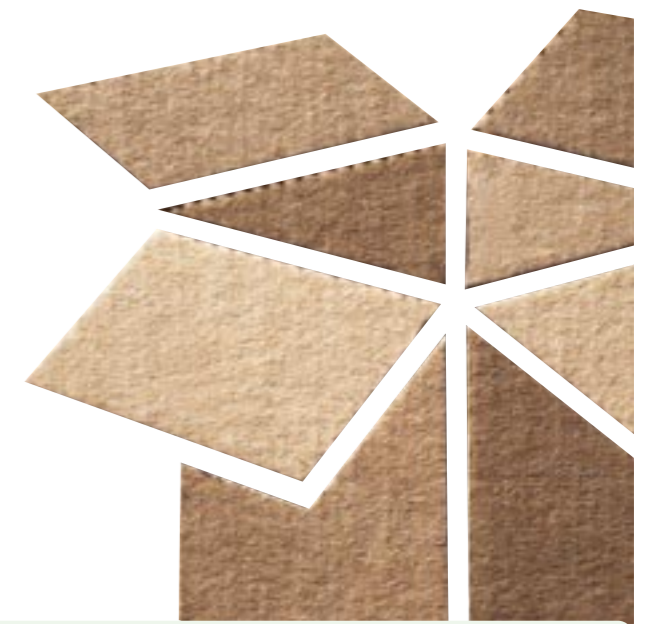

Specifying Corrugated Cartons ▼

This information is intended to help you understand our carton descriptions. We appreciate that there are many variables involved and would therefore recommend a visit by one of our trained representatives to help you achieve a suitable carton for your requirements.

Carton sizes are specified by **Internal** length x breadth x height. Various styles are available specified by FEFCO numbers.

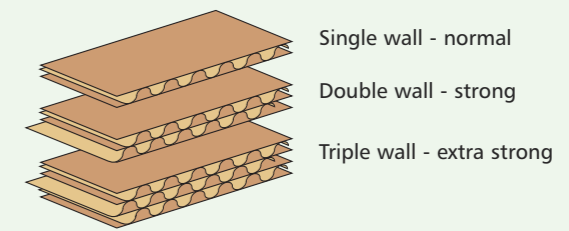

Flute Types

- B flute corrugated- normal, flute height 2.2mm
- C flute corrugated - large, flute height 3.7mm
- E flute corrugated - small, flute height 1.1mm

Paper Types

Kraft Liner - strong, Test Liner - standard, Chip Liner - weak. Paper thicknesses - 125gsm, 150gsm, 200gsm or 300gsm. Cases start as a single sheet of corrugated, where it is joined to itself it can be either glued (normal) or stitched with metal staples (strong) Print detail - can be either plain or printed.

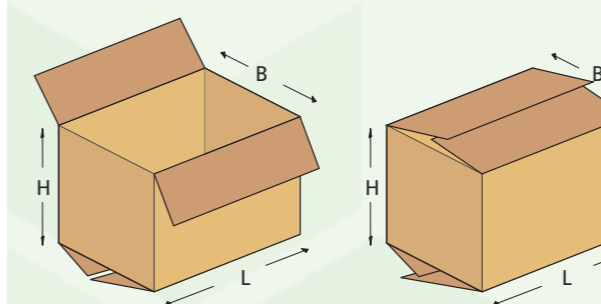

0201 - outer flaps meet

0202 - partial overlap (overlap must be specified)

A carton specified as **300x200x100mm 125K/T B 0201 plain glued** is 300mm long, 200mm wide x 100mm deep internally, made from 125gsm Kraft (outer) and 125gsm Test (inner) with a B flute and is 0201 shaped (code for standard carton) has no print and is glued together.